

***CAST STEEL GATE VALVES
ASME CLASS 900 LBS.***

FIG. VS09

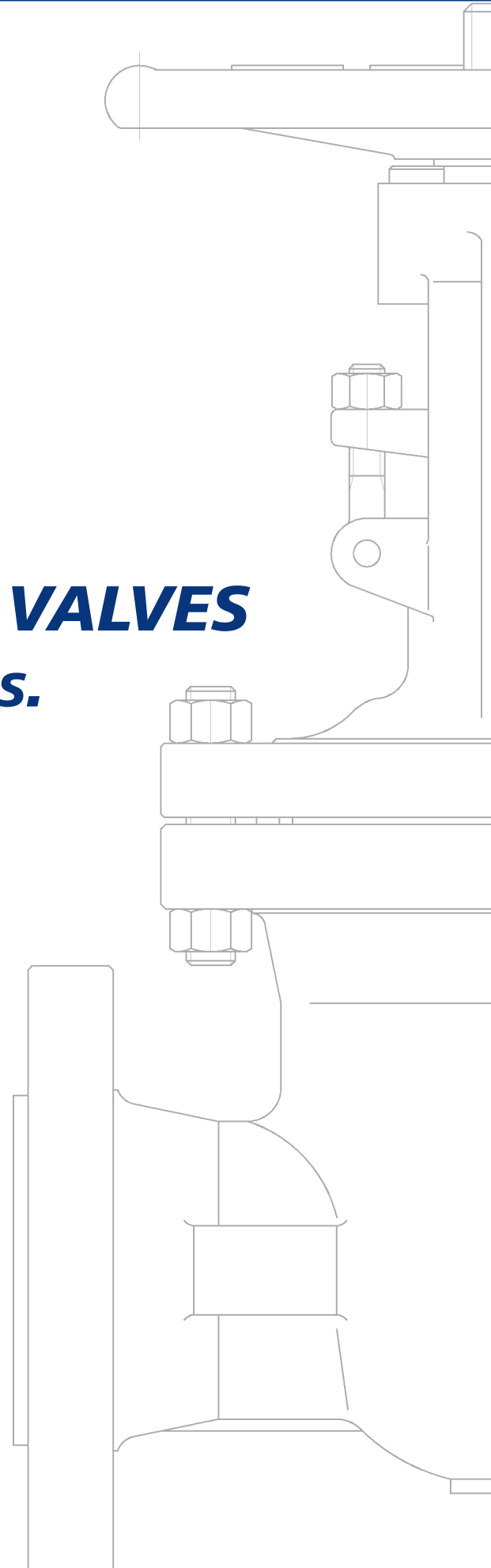

DESCRIPTION AND FEATURES

BOLTED BONNET
OUTSIDE SCREW AND YOKE (OS&Y)
RISING STEM
NON RISING HANDWHEEL
SOLID or FLEXIBLE WEDGE
RENEWABLE SEATS
<i>on request : ISO 5210 TOP FLANGE, LOCKING DEVICE,...</i>
<i>SEE Derval'S SPECIAL FEATURES FOR FURTHER EXECUTION</i>

GENERAL DESIGN SPECIFICATIONS

Design	ASME B16.34 / API600 / BS1414 / ISO 10434
Face to Face	ASME B16.10
End Flange	ASME B16.5 (2" ~ 24") ASME B16.47 (≥ 26")
BW Ends	ASME B16.25
Test	API 598 / API 6D / BS 6755 / EN 12266
Marking	MSS-SP25 / CE P.E.D. (97/23/EC)
Special	NACE MR 01.75 - 01.03 / ATEX 94/9/EC (Ex)

MAXIMUM ALLOWABLE NON-SHOCK WORKING PRESSURE:

T (°C)	-29 ~ 38	50	100	150	200	250	300	350	375	400	425
P (Bar)	153,2	150,2	139,1	135,7	131,5	125,2	116,2	110,9	109,4	103,5	86,3

STANDARD MATERIAL OF PARTS

ITEM	PART NAME	MATERIAL
01	Body	ASTM A216 Gr.WCB
02	Seat Rings	Stellite Gr. 6 Faced
03	Wedge	ASTM A216 Gr.WCB+13Cr Faced
04	Stem	ASTM A182 F6a
05	Gasket *	Soft Iron Ring Joint
06	Bonnet	ASTM A216 Gr. WCB
07	Bonnet Bolt Nuts	ASTM A194 Gr. 2H(M)
08	Bonnet Bolts	ASTM A193 Gr. B7(M)
09	Backseat Bushing	ASTM A276 Type 410
10	Stem Packing *	Braided Graphite & Die Formed Graphite Ring
11	Eye Bolts Pins	Carbon Steel
12	Gland Eyebolt	ASTM A193 Gr. B7(M)
13	Gland	ASTM A276 Type 410
14	Gland Flange	ASTM A216 Gr. WCB
15	Eye Bolt Nuts	ASTM A194 Gr. 2H(M)
16	Grease Nipple	Carbon Steel
17	Stem Nut	ASTM A439 Gr. D-2 / ASTM B148 9A
18	Retaining Nut	Carbon Steel
19	Handwheel	Steel
20	Handwheel Nut	Carbon Steel
21	Screw	Carbon Steel
22	Yoke	ASTM A216 Gr. WCB
23	Yoke Pan Bolt Nuts	ASTM A194 Gr. 2H(M)
24	Yoke Pan Bolts	ASTM A193 Gr. B7(M)
25	Bearing	Steel
26	Lantern Ring <i>On Request</i>	ASTM A276 Type 410

* Recommended Spare Parts

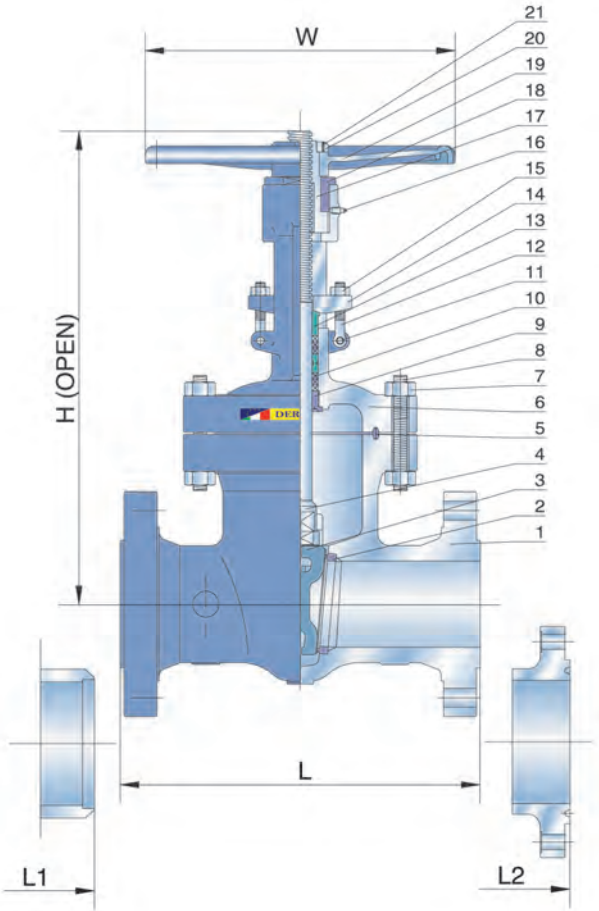

YOKE

FOR 6" & LARGER

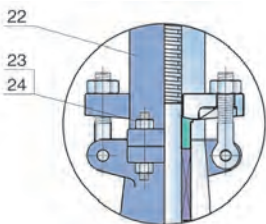

BALL BEARING

FOR 6" & LARGER

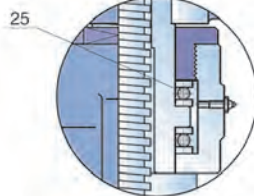

LANTERN RING

ON REQUEST

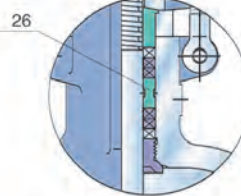

GEAR OPERATOR

RECOMMENDED FOR 6" & LARGER
STANDARD FOR 8" & LARGER

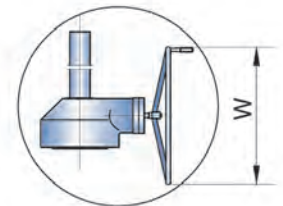

SIZE	mm	50	65	80	100	150	200	250	300	300	400	450	500	600
	<i>inches</i>	2"	2 1/2"	3"	4"	6"	8"	10"	12"	14"	16"	18"	20"	24"
L (RF)	mm	368	419	381	457	610	737	838	965	1029	1130	1219	1321	1549
L1 (BW)	<i>inches</i>	14,50	16,50	15,00	18,00	24,00	29,00	33,00	38,00	40,50	44,50	48,00	52,00	61,00
L2 (RTJ)	mm	371	422	384	460	613	740	841	968	1038	1140	1232	1334	1568
	<i>inches</i>	14,625	16,625	15,125	18,125	24,125	29,125	33,125	38,126	40,875	44,875	48,50	52,50	61,725
H (OPEN)	mm	620	705	737	825	1065	1219	1345	1750	1900	2000	2300	2500	2850
	<i>inches</i>	24,41	27,76	29,02	32,48	41,93	47,99	52,95	68,90	74,80	78,74	90,55	98,43	
W	mm	300	350	350	400	500	600	600	600	600	800	800	800	800
	<i>inches</i>	12	14	14	16	20	24	24	24	24	32	32	32	32
WEIGHT (RF)	Kg.	95	108	125	194	378	635	900	1550	2300	2900	4100	5200	7900
WEIGHT (BW)	Kg.	80	95	105	165	330	520	730	1300	1950	2450	3550	4500	7050

CAST STEEL GATE VALVE STANDARD MATERIALS OF PARTS (ASTM)

The following tables suggest standard combination of body / bonnet materials and trim (seat, stem, disc or wedge) composition. Different composition are available upon request

ITEM	PART NAME	CARBON STEEL		ALLOY STEEL					STAINLESS STEEL			
		TEMPERATURE (°C)	-29 - 427 °C	-46 - 343 °C	-29 - 468 °C	-29 - 593 °C	-29 - 593 °C	-29 - 649 °C	-29 - 649 °C	-196 - 816 °C	-196 - 816 °C	-196 - 427 °C
1	Body	A216 WCB	A352 LCB	A217 WC1	A217 WC6	A217 WC9	A217 C5	A217 C12	A351 CF8	A351 CF8M	A351 CF3	A351 CF3M
2	Seat Ring (1)	A 182 F6a	A182 F304	A 182 F6a	A 182 F6a	A 182 F6a	A 182 F6a	A 182 F6a	A182 F304	A182 F316	A182 F304L	A182 F316L
3	Wedge (2)	A216 WCB	A352 LCB	A217 WC1	A217 WC6	A217 WC9	A217 C5	A217 C12	A351 CF8	A351 CF8M	A351 CF3	A351 CF3M
4	Stem	A 182 F6a	A182 F304	A 182 F6a	A 182 F6a	A 182 F6a	A 182 F6a	A 182 F6a	A182 F304	A182 F316	A182 F304L	A182 F316L
5	Gasket	CL150-300	304(L)+Graphite	304(L) + Graphite	316(L) + Graphite				316(L) + Graphite			
		CL600-2500 Ring Joint	304(L)		316(L)				316(L)			
6	Bonnet	A216WCB	A352LCB	A217 WC1	A217 WC6	A217 WC9	A217 C5	A217 C12	A351 CF8	A351 CF8M	A351 CF3	A351 CF3M
7	Bonnet Bolt Nuts	A194 2H	A194 Gr.4	A194 Gr.4	A194 Gr.4	A194 Gr.4	A194 Gr.4	A194 Gr.4	A194 Gr.8	A194 Gr.8M	A194 Gr.8	A194 Gr.8M
8	Bonnet Bolts	A193 B7	A193 L7	A193 B16	A193 B16	A193 B16	A193 B16	A193 B16	A193 B8	A193 B8M	A193 B8	A193 B8M
9	Backseat Bushing	A276 410	A276 304	A276 304	A276 304	A276 304	A276 304	A276 304	A276 304	A276 316	A276 304L	A276 316L
10	Stem Packing	Braided Graphite & Die Formed Graphite Ring		Braided Graphite & Die Formed Graphite Ring				Braided Graphite & Die Formed Graphite Ring				
11	Eye Bolt Pins	Carbon steel		A276 410				Stainless Steel				
12	Gland Eye Bolts	A193 B7	A193 L7	A193 B16	A193 B16	A193 B16	A193 B16	A193 B16	A193 B8	A193 B8M	A193 B8	A193 B8M
13	Gland	A276 410	A276 304	A276 410				A276 304				
14	Gland Flange	A216 WCB	A352 LCB	A217 WC1	A217 WC6	A217 WC9	A217 C5	A217 C12	A351 CF8	A351 CF8M	A351 CF3	A351 CF3M
15	Eye Bolt Nuts	A194 2H	A194 Gr.4	A194 Gr.4	A194 Gr.4	A194 Gr.4	A194 Gr.4	A194 Gr.4	A194 Gr.8	A194 Gr.8M	A194 Gr.8	A194 Gr.8M
16	Grease Nipple	Carbon steel		Alloy steel				Stainless Steel				
17	Stem Nut	A439 D2C / B148 9A		A439 D2C / B148 9A				A439 D2C / B148 9A				
18	Retaining Nut	Carbon steel		Alloy steel				Stainless Steel				
19	Handwheel	Steel		Steel				Steel				
20	Handwheel Nut	Carbon steel		Alloy steel				Stainless Steel				
21	Screw	Carbon steel		Alloy steel				Stainless Steel				
22	Yoke	A216 WCB	A352 LCB	A217 WC1	A217 WC6	A217 WC9	A217 C5	A217 C12	A351 CF8	A351 CF8M	A351 CF3	A351 CF3M
23	Yoke Pan Bolt Nuts	A194 2H	A194 Gr.4	A194 Gr.4	A194 Gr.4	A194 Gr.4	A194 Gr.4	A194 Gr.4	A194 Gr.8	A194 Gr.8M	A194 Gr.8	A194 Gr.8M
24	Yoke Pan Bolts	A193 B7	A193 L7	A193 B16	A193 B16	A193 B16	A193 B16	A193 B16	A193 B8	A193 B8M	A193 B8	A193 B8M
25	Bearing	Steel		Steel				Steel				
26	Lantern Ring On Request	A276 410	A276 304	A276 304				A276 304	A276 316	A276 304L	A276 316L	

(1): Base material shall be at least equal in corrosion resistance to the body material (Acc. to API 600 Std.)

(2): Base material only. See trim material for wedge surface

Stainless Steel: At temperatures over 538°C, use the material only when the carbon contents is 0.04% or higher.

Derval S.r.l. reserves the right to substitute materials listed above with alternative material approved for designated service

TRIM MATERIALS (API 600 STANDARD)

The API TRIM N° 8 is supplied on Derval Valves as standard trim. Materials for other trims are in accordance with the following table. Other trims also according to customer's requirement.

TRIM N°	1	2	5	8	9	10	11	12	13	14	15	16	17
DERVAL DESCRIPTION	F6	304	F6-HF	F6-HFS	Monel	316	Monel-HFS	316-HFS	Alloy 20	Alloy 20-HFS	304-HF	316-HF	347-HF
2	Seat Surface	13Cr.	304	HF	HF	Monel	316	HF	HF	Alloy 20	HF	HF	HF
3	Wedge Surface	13Cr.	304	HF	13Cr.	Monel	316	Monel	316	Alloy 20	HF	HF	HF
4	Stem	F6	F304	F6	F6	Monel	F316	Monel	F316	Alloy 20	F304	F316	F347
9	Backseat Bushing	F6	304	F6	F6	Monel	316	Monel	316	Alloy 20	304	316	347

Note: The chart above only lists out some common composition of steel gate valve parts. We may provide other different parts material composition according to the customer's request or based on the actual valve working condition.

PRESSURE - TEMPERATURE RATINGS

The following pressure-temperature charts are derived from ASME B16.34. They will cover the most commonly used body and bonnet materials in the industry. All Derval Valves are designed to operate through the pressure and temperature ranges shown in these charts for a particular ASME Class Rating and ASTM Material.

Pressure temperature ratings are based on ASME B16.34 (bar/°C)

ASTM GROUP MATERIAL STANDARD – TO ASME B16.34

ASME 900

SERVICE TEMPERATURE °C	ASTM MATERIALS											
	Group 1.1	Group 1.3	Group 1.5	Group 1.9	Group 1.10	Group 1.13	Group 1.14	Group 2.1	Group 2.2	Group 2.1	Group 2.2	
	A216 WCB (a)	A352 LCB (b)	A217 WC1 (c)	A217 WC6 (d)	A217 WC9 (e)	A217 C5	A217 C12	CF8 (e)	CF8M (e)	CF3 (f)	CF3M (g)	
WORKING PRESSURES (bar)												
-29 to 38	153,2	143,6	143,6	155,1	155,1	155,2	155,2	148,9	148,9	148,9	148,9	
50	150,2	141,9	142,9	153,4	153,6	155,2	155,2	143,5	144,4	143,5	144,4	
100	139,1	135,3	139,8	146,3	147,1	154,6	154,6	122,6	126,6	122,6	126,6	
150	135,7	131,9	134,9	139,1	139,9	150,6	150,6	109,0	115,5	109,0	115,5	
200	131,5	128,0	132,6	136,4	134,5	146,4	146,4	98,3	107,0	98,3	107,0	
250	125,2	121,8	129,2	133,4	132,7	139,0	139,0	91,6	100,2	91,6	100,2	
300	116,2	113,1	126,1	127,3	127,3	127,3	127,3	87,2	94,9	87,2	94,9	
350	110,9	107,9	120,7	120,7	120,7	120,7	120,7	84,2	91,3	84,2	91,3	
400	103,5	-	109,8	109,8	109,8	109,8	109,8	82,4	87,3	82,4	87,3	
425	86,3	-	105,3	105,3	105,3	103,5	105,3	81,5	86,0	81,5	86,0	
450	60,1	-	101,4	101,4	101,4	92,7	101,4	80,6	84,2	80,6	84,2	
500	26,4	-	72,2	83,4	83,4	60,8	82,5	78,2	80,5	-	80,5	
525	15,5	-	45,1	60,8	65,8	46,3	67,8	71,6	78,9	-	-	
540	9,8	-	32,1	38,3	49,1	35,0	50,9	65,4	74,9	-	-	
600	-	-	-	17,6	22,9	19,6	21,5	50,1	64,3	-	-	
650	-	-	-	7,0	11,0	9,0	10,4	31,6	42,4	-	-	
700	-	-	-	-	-	-	-	17,9	29,8	-	-	
750	-	-	-	-	-	-	-	11,0	17,6	-	-	
800	-	-	-	-	-	-	-	6,2	10,5	-	-	
(Hydr.) Shell Test	229,8	215,4	215,4	232,7	232,7	232,8	232,8	223,4	223,4	223,4	223,4	
(Hydr.) Seat Test	168,5	158,0	158,0	170,6	170,6	170,7	170,7	163,8	163,8	163,8	163,8	
(Pneum.) Seat Test	5,5	5,5	5,5	5,5	5,5	5,5	5,5	5,5	5,5	5,5	5,5	

a) Permissible, but not recommended for prolonged usage above 427°C (800°F)

b) Not to be used over 343°C (650°F)

c) Permissible, but not recommended for prolonged usage above 468°C (875°F)

d) Not to be used over 593°C (1100°F)

e) At temperature over 538°C (1000°F), use only when carbon content is 0,04 or higher

f) Not to be used over 427°C (800°F)

g) Not to be used over 454°C (850°F)

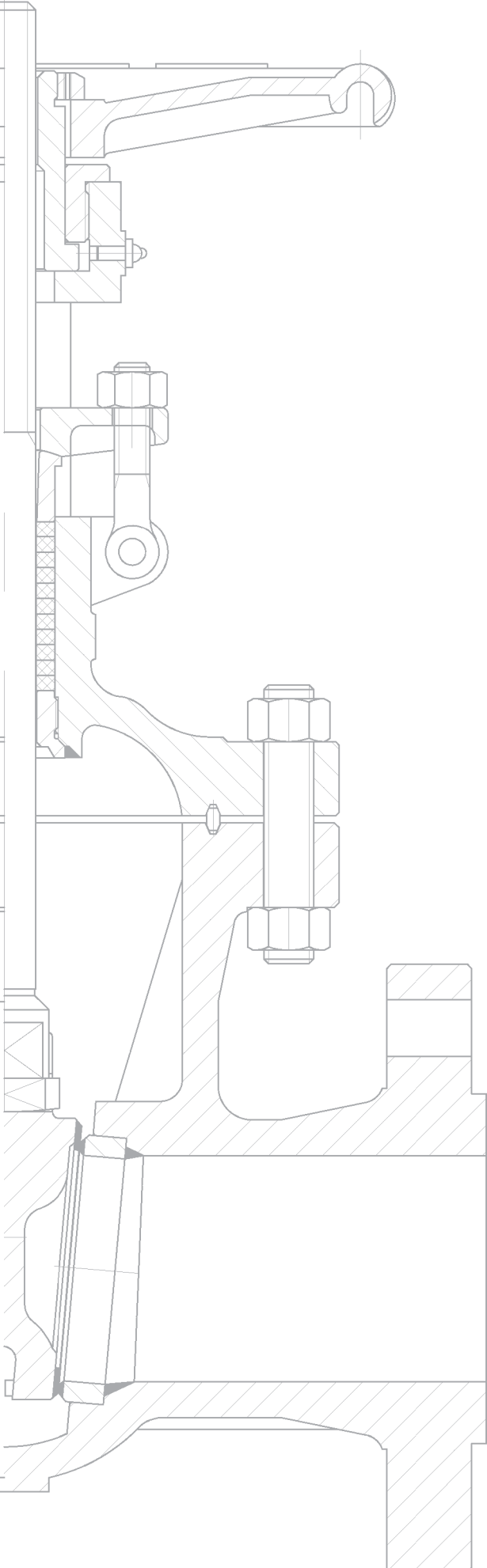

APPLICATION:

Derval gate valves are used as efficient shut-off valves with flow in either direction for water, saturated steam, air, gas, oil and crude oil products. They are utilized in applications where minimum pressure drop is necessary.

Due to their specific design, gate valves should be operated in the full-open or full-close position. Concentrated flow across the seats of a partially opened gate valve risks possible seat damage, therefore throttling is not recommended.

Operating parameters are in accordance with ASME B16.34 standard.

INSTALLATION:

Derval gate valves are normally installed in horizontal pipe with vertical stem (handwheel up).

The high quality Derval valves are installed in a large variety of services in the Oil & Gas field, Chemical and Petrochemical industry, in On-shore and Off-shore drilling/refining, Power Generation, Water and Wastewater Treatment industries.

 **DERVAL** s.r.l.

DERVAL S.R.L.

VIA GUIDO ROSSA, 13

20024 GARBAGNATE MILANESE

(MILANO) - ITALY

PHONE: +39 02 990.20.302

FAX: +39 02 990.25.461

WEB: www.derval.it

E-MAIL: info@derval.it