



DERVAL s.r.l.

**CAST STEEL
SWING CHECK
ASME CLASS 900 LBS.**

DER
INDUSTRIAL VALVES

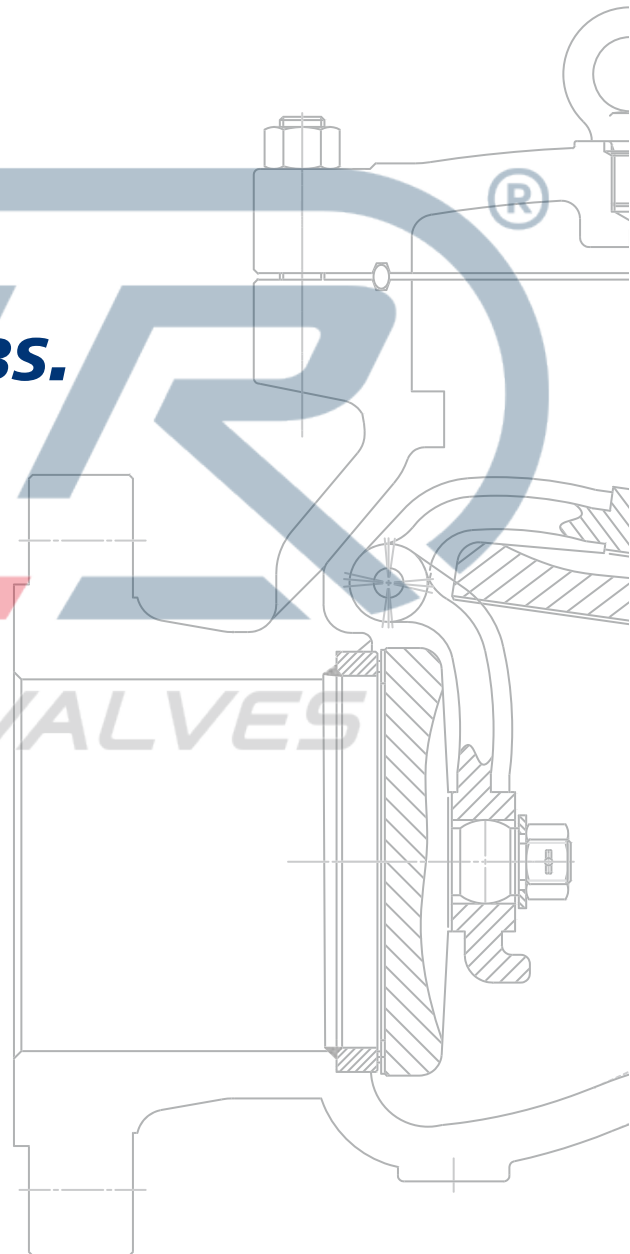

FIG. CH 09

DESCRIPTION AND FEATURES

BOLTED COVER
FULL OPENING TYPE
SWING TYPE DISC
INTERNAL or EXTERNAL HINGE PIN
LAPPED DISC AND SEAT
RENEWABLE SEAT
<i>on request: WITH BY-PASS, LEVER AND WEIGHT,...</i>
<i>SEE Derval's SPECIAL FEATURES FOR FURTHER EXECUTION</i>

GENERAL DESIGN SPECIFICATIONS

Design	ASME B16.34 / API 6D / BS1868
Face to Face	ASME B16.10
End Flange	ASME B16.5 (2" ~ 24") ASME B16.47 (≥ 26")
BW Ends	ASME B16.25
Test	API 598 / API 6D / EN 12266-1
Marking	MSS-SP25 / CE P.E.D. (2014/68/EU)
Special	NACE MR 01.75 - 01.03/ATEX 2014/34/EU(Ex)

MAXIMUM ALLOWABLE NON-SHOCK WORKING PRESSURE:

T (°C)	-29 ~ 38	50	100	150	200	250	300	350	375	400	425
P (Bar)	153,2	150,2	139,1	135,7	131,5	125,2	116,2	110,9	109,4	103,5	86,3

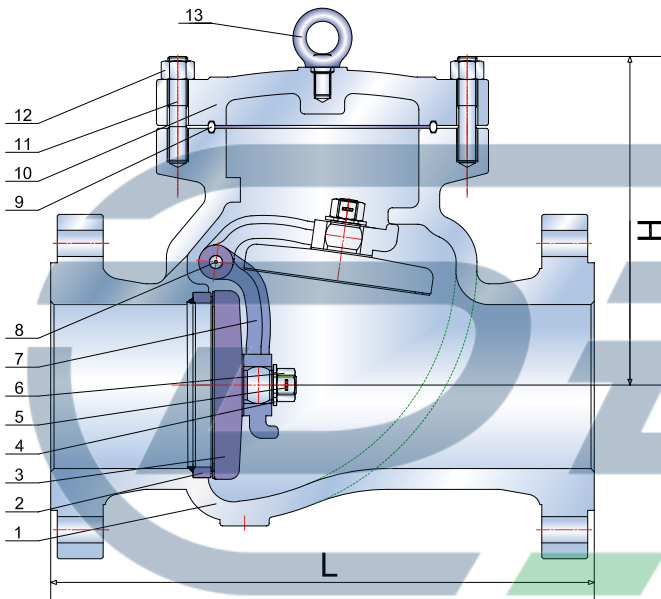

STANDARD MATERIAL OF PARTS

ITEM	PART NAME	MATERIAL
01	Body	ASTM A216 Gr.WCB
02	Seat Rings	Stellite Gr. 6 Faced
03	Disc	ASTM A216 Gr.WCB+13Cr Faced
04	Disc Washer	ASTM A276 Type 410
05	Disc Nut Pin	Stainless Steel
06	Disc Nut	Stainless Steel
07	Hinge	ASTM A216 Gr.WCB
08	Hinge Pin	ASTM A182 F6a
09	Gasket	Soft Iron Ring Joint
10	Cover	ASTM A216 Gr.WCB
11	Cover Bolt	ASTM A193 Gr. B7(M)
12	Cover Bolt Nut	ASTM A194 Gr. 2H(M)
13	Eye Bolt	Carbon Steel
14	Plug	Carbon Steel

INDUSTRIAL VALVES

Hinge pin passing through Body and sealed by Plug

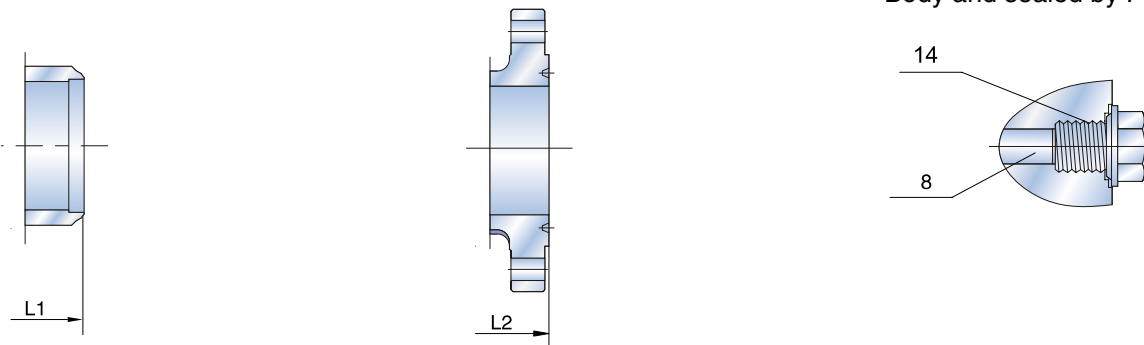

SIZE	mm	50	65	80	100	150	200	250	300	350	400	450	500	600
	inches	2"	2 1/2"	3"	4"	6"	8"	10"	12"	14"	16"	18"	20"	24"
L (RF)	mm	368	419	381	457	610	737	838	965	1029	1130	1219	1321	1549
L1 (BW)	inches	14,50	16,50	15,00	18,00	24,00	29,00	33,00	38,00	40,50	44,50	48,00	52,00	61,00
L2 (RTJ)	mm	371	422	384	460	613	740	841	968	1038	1140	1232	1334	1568
	inches	14,62	16,62	15,12	18,12	24,12	29,12	33,12	38,12	40,87	44,87	48,50	52,50	61,75
H	mm	270	280	300	320	430	502	560	650	700	780	880	1050	1200
	inches	10,63	11,02	11,81	12,60	16,93	19,76	22,05	25,59	27,56	30,71	34,65	41,34	47,24
WEIGHT (RF)	Kg.	65	80	90	150	300	450	810	1100	1250	1790	2500	3080	4600
WEIGHT (BW)	Kg.	55	65	70	125	255	335	610	830	900	1290	1950	2400	3700

CAST STEEL SWING CHECK VALVE STANDARD MATERIALS OF PARTS (ASTM)

The following tables suggest standard combination of body / cover materials and trim (seat and disc) composition. Different composition are available upon request.

ITEM	PART NAME	CARBON STEEL		ALLOY STEEL					STAINLESS STEEL			
		-29 ~ 427 °C	LOW TEMP. CARBON STEEL -46 ~ 343 °C	-29 ~ 468 °C	-29 ~ 593 °C	-29 ~ 593 °C	-29 ~ 649 °C	-29 ~ 649 °C	-196 ~ 816 °C	-196 ~ 816 °C	-196 ~ 427 °C	-196 ~ 454 °C
1	Body	A216 WCB	A352 LCB	A217 WC1	A217 WC6	A217 WC9	A217 C5	A217 C12	A351 CF8	A351 CF8M	A351 CF3	A351 CF3M
2	Seat Ring (1)	A 182 F6a	A182 F304	A 182 F6a	A 182 F6a	A 182 F6a	A 182 F6a	A 182 F6a	A182 F304	A182 F316	A182 F304L	A182 F316L
3	Disc (2)	A216 WCB	A352 LCB	A217 WC1	A217 WC6	A217 WC9	A217 C5	A217 C12	A351 CF8	A351 CF8M	A351 CF3	A351 CF3M
4	Disc washer	A276 410	A276 304	A276 316								
5	Disc Nut Pin	Stainless Steel		Stainless Steel					Stainless Steel			
6	Disc Nut	Stainless Steel		Stainless Steel					Stainless Steel			
7	Hinge	A216 WCB	A352 LCB	A217 WC1	A217 WC6	A217 WC9	A217 C5	A217 C12	A351 CF8	A351 CF8M	A351 CF3	A351 CF3M
8	Hinge Pin	A 182 F6a	A182 F304	A 182 F6a	A 182 F6a	A 182 F6a	A 182 F6a	A 182 F6a	A182 F304	A182 F316	A182 F304L	A182 F316L
9	Gasket	CL150-300	304(L)+Graphite	316(L) + Graphite					316(L) + Graphite			
		CL600-2500 Ring Joint	304(L)	316(L)					316(L)			
10	Cover	A216 WCB	A352 LCB	A217 WC1	A217 WC6	A217 WC9	A217 C5	A217 C12	A351 CF8	A351 CF8M	A351 CF3	A351 CF3M
11	Cover Bolt	A193 B7	A193 L7	A193 B16	A193 B16	A193 B16	A193 B16	A193 B16	A193 B8	A193 B8M	A193 B8	A193 B8M
12	Cover Bolt Nut	A194 2H	A194 Gr.7	A194 Gr.4	A194 Gr.4	A194 Gr.4	A194 Gr.4	A194 Gr.4	A194 Gr.8	A194 Gr.8M	A194 Gr.8	A194 Gr.8M
13	Eye Bolt	Carbon Steel	Low Carbon Steel	Alloy Steel					Stainless Steel			
14	Plug	A105N	A350 LF2	A182 F1	A182 F11	A182 F22	A182 F5a	A182 F9	A182 F304	A182 F316	A182 F304L	A182 F316L

(1): Base material shall be at least equal in corrosion resistance to the body material (Acc. to API 600 Std.)

(2): Base material only. See trim material for wedge surface

Stainless Steel: At temperatures over 538°C, use the material only when the carbon contents is 0.04% or higher.

Derval S.r.l. reserves the right to substitute materials listed above with alternative material approved for designated service.

TRIM MATERIALS (API 600 STANDARD)

The API TRIM N° 8 is supplied on Derval Valves as standard trim. Materials for other trims are in accordance with the following table. Other trims also according to customer's requirement.

TRIM N°	1	2	5	8	9	10	11	12	13	14	15	16	17
DERVAL DESCRIPTION	F6	304	F6-HF	F6-HFS	Monel	316	Monel-HFS	316-HFS	Alloy 20	Alloy 20-HFS	304-HF	316-HF	347-HF
2 Seat Surface	13Cr.	304	HF	HF	Monel	316	HF	HF	Alloy 20	HF	HF	HF	HF
3 Disc Surface	13Cr.	304	HF	13Cr.	Monel	316	Monel	316	Alloy 20	Alloy 20	HF	HF	HF
8 Hinge Pin	F6	F304	F6	F6	Monel	F316	Monel	F316	Alloy 20	Alloy 20	F304	F316	F347

Note: The chart above only lists out some common composition of Swing Check valve parts. We may provide other different parts material composition according to the customer's request or based on the actual valve working condition.

PRESSURE - TEMPERATURE RATINGS

The following pressure-temperature charts are derived from ASME B16.34. They will cover the most commonly used body and bonnet materials in the industry.

All Derval Valves are designed to operate through the pressure and temperature ranges shown in these charts for a particular ASME Class Rating and ASTM Material.

Pressure temperature ratings are based on ASME B16.34 (bar/°C)

ASTM GROUP MATERIAL STANDARD - TO ASME B16.34

ASME 900

SERVICE TEMPERATURE °C	ASTM MATERIALS											
	Group 1.1 A216 WCB (a)	Group 1.3 A352 LCB (b)	Group 1.5 A217 WC1 (c)	Group 1.9 A217 WC6 (d)	Group 1.10 A217 WC9 (e)	Group 1.13 A217 C5	Group 1.14 A217 C12	Group 2.1 CF8 (e)	Group 2.2 CF8M (e)	Group 2.1 CF3 (f)	Group 2.2 CF3M (g)	
	WORKING PRESSURES (bar)											
-29 to 38	153,2	143,6	143,6	155,1	155,1	155,2	155,2	148,9	148,9	148,9	148,9	
50	150,2	141,9	142,9	153,4	153,6	155,2	155,2	143,5	144,4	143,5	144,4	
100	139,1	135,3	139,8	146,3	147,1	154,6	154,6	122,6	126,6	122,6	126,6	
150	135,7	131,9	134,9	139,1	139,9	150,6	150,6	109,0	115,5	109,0	115,5	
200	131,5	128,0	132,6	136,4	134,5	146,4	146,4	98,3	107,0	98,3	107,0	
250	125,2	121,8	129,2	133,4	132,7	139,0	139,0	91,6	100,2	91,6	100,2	
300	116,2	113,1	126,1	127,3	127,3	127,3	127,3	87,2	94,9	87,2	94,9	
350	110,9	107,9	120,7	120,7	120,7	120,7	120,7	84,2	91,3	84,2	91,3	
400	103,5	-	109,8	109,8	109,8	109,8	109,8	82,4	87,3	82,4	87,3	
425	86,3	-	105,3	105,3	105,3	103,5	103,5	81,5	86,0	81,5	86,0	
450	60,1	-	101,4	101,4	101,4	92,7	101,4	80,6	84,2	80,6	84,2	
500	26,4	-	72,2	83,4	83,4	60,8	82,5	78,2	80,5	-	80,5	
525	15,5	-	45,1	60,8	65,8	46,3	67,8	71,6	78,9	-	-	
540	9,8	-	32,1	38,3	49,1	35,0	50,9	65,4	74,9	-	-	
600	-	-	-	17,6	22,9	19,6	21,5	50,1	64,3	-	-	
650	-	-	-	7,0	11,0	9,0	10,4	31,6	42,4	-	-	
700	-	-	-	-	-	-	-	17,9	29,8	-	-	
750	-	-	-	-	-	-	-	11,0	17,6	-	-	
800	-	-	-	-	-	-	-	6,2	10,5	-	-	
(Hydr.) Shell Test	229,8	215,4	215,4	232,7	232,7	232,8	232,8	223,4	223,4	223,4	223,4	
(Hydr.) Seat Test	168,5	158,0	158,0	170,6	170,6	170,7	170,7	163,8	163,8	163,8	163,8	
(Pneum.) Seat Test	5,5	5,5	5,5	5,5	5,5	5,5	5,5	5,5	5,5	5,5	5,5	

a) Permissible, but not recommended for prolonged usage above 427°C (800°F)

b) Not to be used over 343°C (650°F)

c) Permissible, but not recommended for prolonged usage above 468°C (875°F)

d) Not to be used over 593°C (1100°F)

e) At temperature over 538°C (1000°F), use only when carbon content is 0,04 or higher

f) Not to be used over 427°C (800°F)

g) Not to be used over 454°C (850°F)

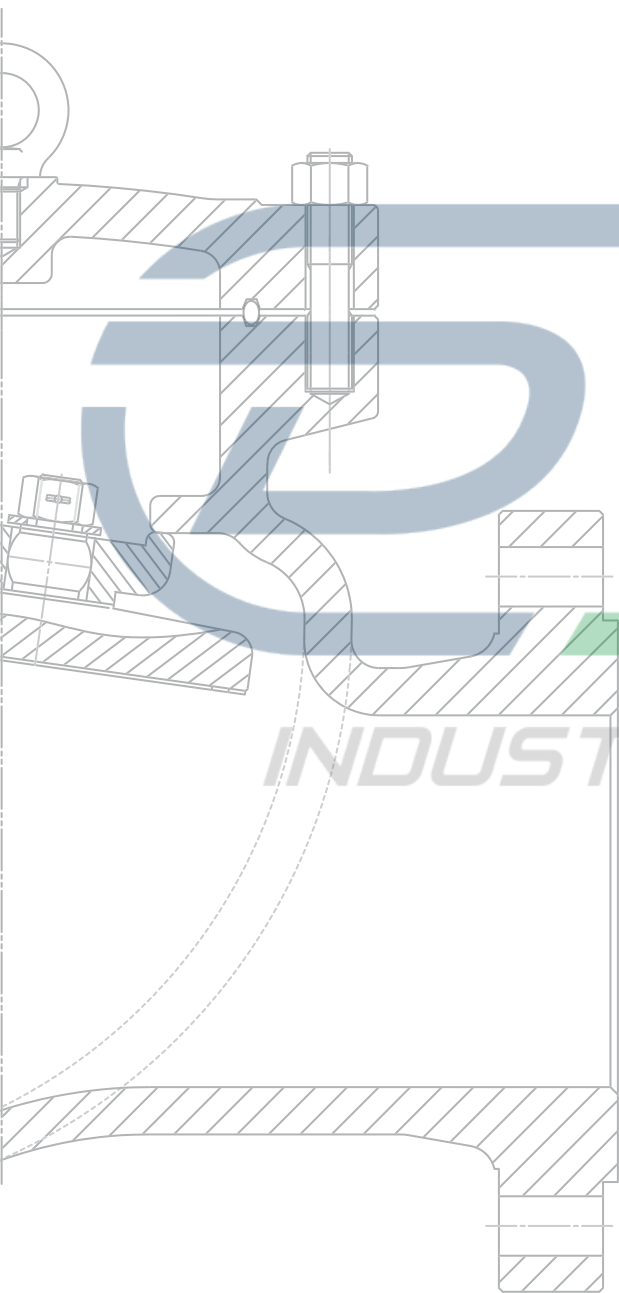

APPLICATION:

Swing Check valves prevent reversal of flow through pipe lines. Most Derval Swing Check valves can be installed in horizontal or vertical, upward flow, piping. They offer low resistance to flow and are particularly suited to low velocity service.

They are widely used for water, saturated steam, air, gas, oil and crude oil products. Operating parameters are in accordance with ASME B16.34 standard.

INSTALLATION:

Swing check valves can be installed either horizontally or vertically.

If installed vertically, disc must be in upper position and flow direction must be upwards (under disc).

The high quality Derval valves are installed in a large variety of services in the Oil & Gas field, Chemical and Petrochemical industry, in On-shore and Off-shore drilling/refining, Power Generation and Water and Waste Treatment industries.

 **DERVAL** s.r.l.

DERVAL S.R.L.

VIA GUIDO ROSSA, 13

20024 GARBAGNATE MILANESE

(MILANO) - ITALY

PHONE: +39 02 990.20.302

FAX: +39 02 990.25.461

WEB: www.derval.it

E-MAIL: info@derval.it